

```
/*      NOT_LS */
module NOT_LS ( IN, OUT );
input  IN;
output OUT;
      not    #( 15, 15 )    U1    ( OUT , IN );
endmodule
```

```
/*      NOT_F      */  
module NOT_F ( IN, OUT );  
input  IN;  
output OUT;  
      not      #( 6, 5.3 )      U2      ( OUT , IN );  
endmodule
```

```
/*      NOT_LS  */
module NOT_LS ( IN, OUT );
input  IN;
output OUT;
parameter      LS04_TPLH = 15;
parameter      LS04_TPHL = 15;

        assign #( LS04_TPLH, LS04_TPHL )      OUT = ~IN;
endmodule
```

```
/*      NOT_F      */
module NOT_F ( IN, OUT );
input  IN;
output OUT;
parameter      F04_TPLH = 6;
parameter      F04_TPHL = 5.3;
        assign #( F04_TPLH, F04_TPHL )      OUT = ~IN;
endmodule
```

```
/*      AND_AS */
module AND_AS ( IN_1, IN_2, OUT );
input  IN_1, IN_2;
output OUT;
parameter      AS08_TPLH = 5.5;
parameter      AS08_TPHL = 5.5;

        assign #( AS08_TPLH, AS08_TPHL )      OUT = IN_1 & IN_2;
endmodule
```

```
/*      AND      */  
module AND      ( IN, OUT );  
input  IN;  
output OUT;  
tri1   IN_PUP;  
      assign OUT = IN & IN_PUP;  
endmodule
```

```
/*      OR      */  
module OR      ( IN, OUT );  
input  IN;  
output OUT;  
tri0   IN_PDO;  
      assign OUT = IN | IN_PDO;  
endmodule
```

```
/*      TRI_BUF */
module TRI_BUF ( IN_A, IN_B, IN_C, EN_A, EN_B, EN_C, OUT );
input  IN_A, IN_B, IN_C;
input  EN_A, EN_B, EN_C;
output OUT;
tri    TRI_OR;
      bufif1 U1    ( TRI_OR, IN_A, EN_A );
      bufif1 U2    ( TRI_OR, IN_B, EN_B );
      bufif1 U3    ( TRI_OR, IN_C, EN_C );
      buf    U4    ( OUT, TRI_OR );
endmodule
```



```

/*      TRI_BUF */
module TRI_BUF ( IN_A, IN_B, IN_C, EN_A, EN_B, EN_C, OUT );
input  IN_A, IN_B, IN_C;
input  EN_A, EN_B, EN_C;
output OUT;
tri    TRI_OR;
      assign TRI_OR = TRI_BUF_G ( IN_A, EN_A );
      assign TRI_OR = TRI_BUF_G ( IN_B, EN_B );
      assign TRI_OR = TRI_BUF_G ( IN_C, EN_C );
      assign OUT    = TRI_OR;

      function      TRI_BUF_G;
      input  IN, EN;

          TRI_BUF_G = ( EN )? IN: 1'bz;

      endfunction
endmodule

```

```

/*      PROB_2  */
module PROB_2 ( A, B, C, OUT );
input  A, B, C;
output OUT;
wire   ASTR_1, ASTR_2, ASTR_3;
tri1   IN_PUP;
parameter      AS00_TPLH = 4.5;
parameter      AS00_TPHL = 4;

        assign #( AS00_TPLH, AS00_TPHL )      ASTR_3 = ~( C & IN_PUP );
        assign #( AS00_TPLH, AS00_TPHL )      ASTR_1 = ~( A & C );
        assign #( AS00_TPLH, AS00_TPHL )      ASTR_2 = ~( B & ASTR_3 );
        assign #( AS00_TPLH, AS00_TPHL )      OUT   = ~( ASTR_1 & ASTR_2 );
endmodule

```

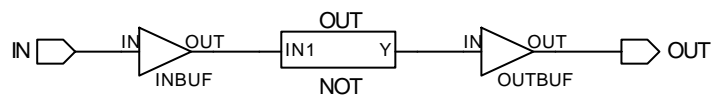

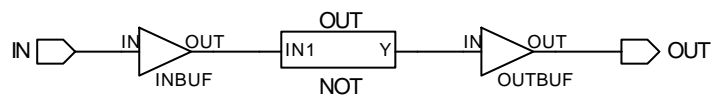

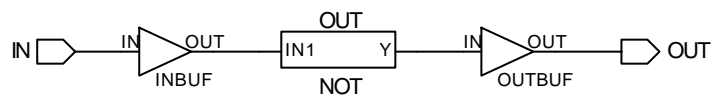

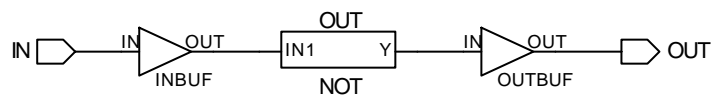

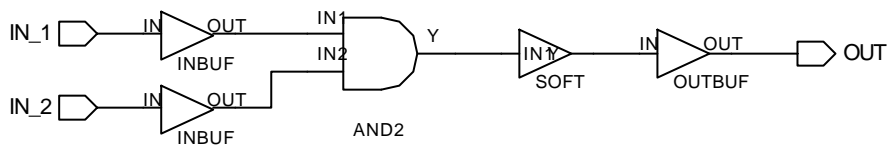

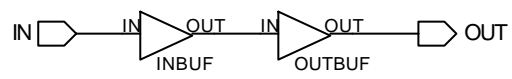

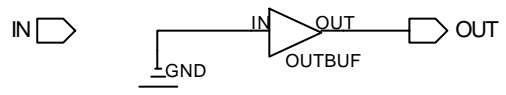

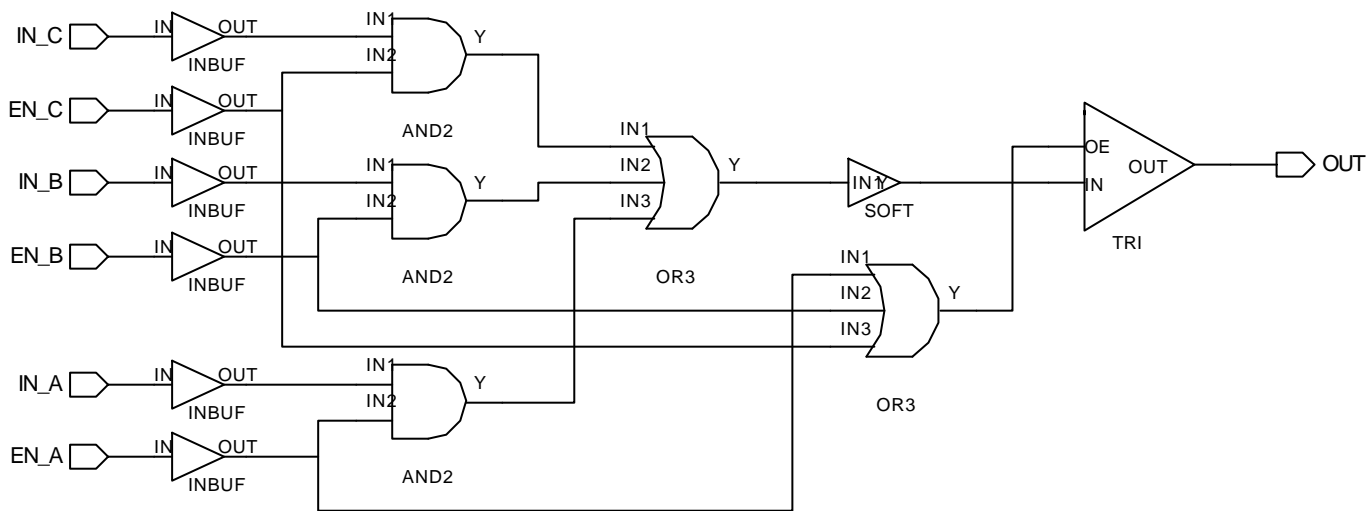

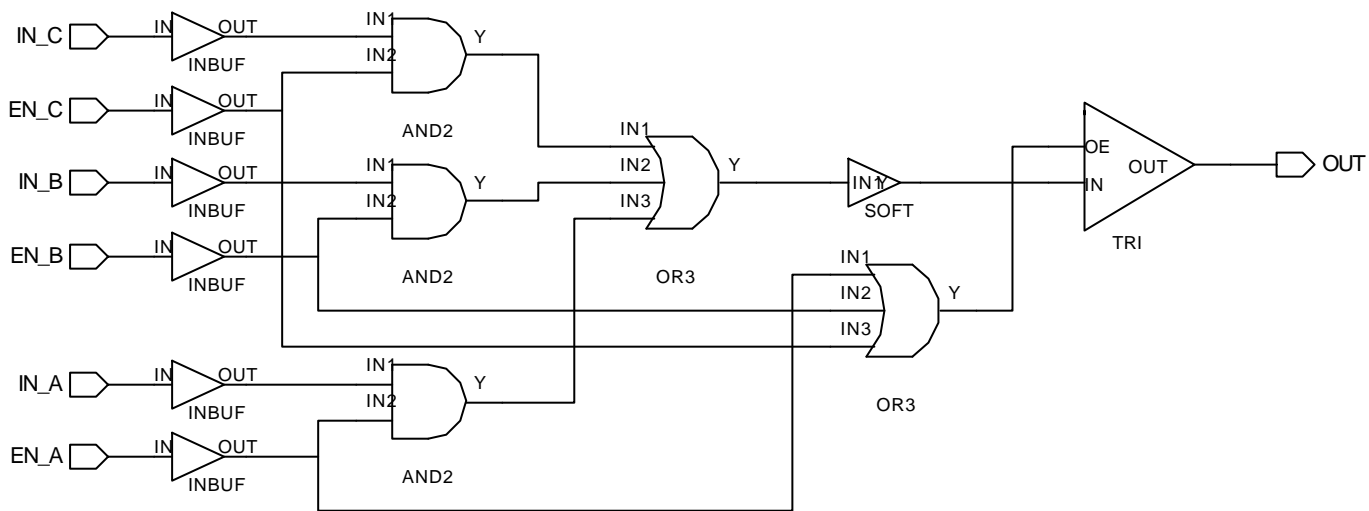

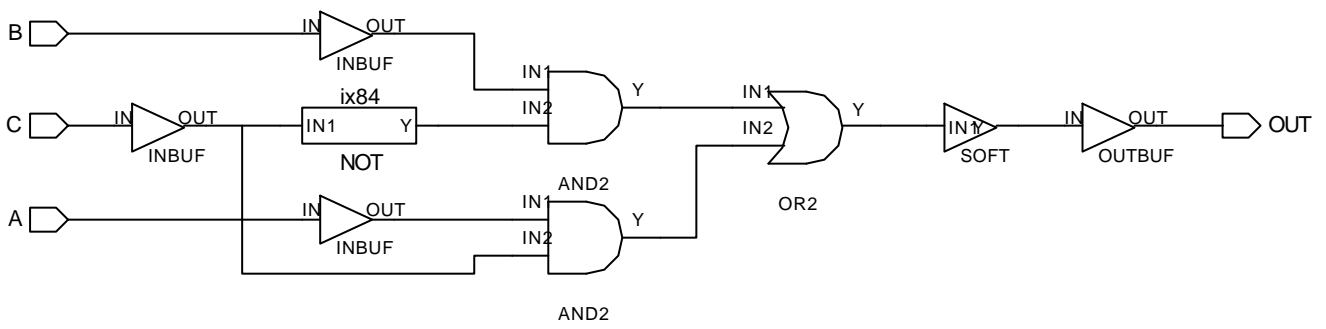

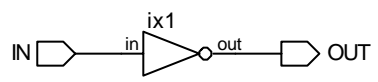

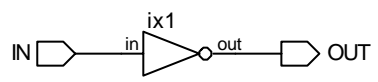

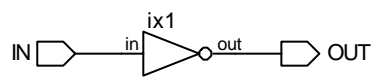

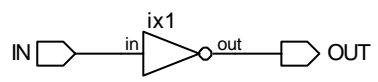

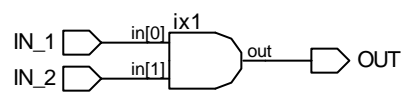



IN   OUT

